

SHARKY FS 473

FLOW SENSOR | ULTRASONIC

DIEHL
Metering



APPLICATION

The ultrasonic flow sensor can be used for flow measuring in local and district heating / cooling systems.

FEATURES

- ▶ Dynamic range (DR) of up to 1:250 ($q_i:q_p$) in class 2 (depends on meter size), standard 1:100
- ▶ Extreme low power consumption --> longer battery lifetime
- ▶ Approved according EN 1434 and MID in class 2 and 3 and PTB K 7.2 (cooling)
- ▶ High long term stability
- ▶ Applicable for different calculators with impulse input
- ▶ Continuous time-correct pulses - no pulse packages
- ▶ Free selectable impulse values
- ▶ The temperature range depending on the application up to 5 ... 150 °C
- ▶ Battery or external power supply
- ▶ Specific housing for falling and rising pipes

SHARKY FS 473

FLOW SENSOR | ULTRASONIC

GENERAL

SHARKY FS 473	
Application	Heating - cooling
Approval	MID (DE-07-MI004-PTB022) and PTB K 7.2 for cooling (22.76/10.01)
Ambient class	EN 1434 class C / MID class E2 + M2
Ambient temperature	°C 5 ... 55 (<35 °C have a positive lifetime effect)
Battery supply	3.0 VDC battery - up to 12 years lifetime
External supply	3.0 ... 5.5 VDC
Mounting position	Any position
Protection class	Heating: IP 54; heating potted: IP 65; cooling: IP 65
Interfaces	Open Collector pulse output ¹ - output for testing and communication ²
Volume pulse value ³	10 ml ... 5000 l/pulse (depending on sensor sizes and supply)
Cable length of impulse cable	2.4 m (4.9 or 9.9 m optional)
Material of the flow sensor body	Brass (q_p 0.6 ... 100 m ³ /h), spheroidal cast iron (q_p 15 ... 100 m ³ /h)

¹ The pulse output can be chosen without galvanic isolation (standard) or with galvanic isolation (only with battery supply). The flow sensor has by default a 4-wire impulse cable.

² The flow sensor can either emit a high resolution test pulse (standard) or communicate via the same output. By using an adapter the flow sensor can be read via the HYDRO-SET software.

³ The pulse duration is between 1 and 250 ms. It depends on the pulse value and on the nominal flow rate q_p .
Standard pulse values: 1, 2.5, 10, 25, 100, 250 l/pulse

TEMPERATURE RANGE

SHARKY FS 473	
Temperature range heating - battery supplied	°C 5 ... 90 / 5 ... 105 ¹
Temperature range heating - external supplied	°C 5 ... 105 / 130 / 150 (depends on meter size and material)
Temperature range cooling - battery supplied / external supplied	°C 5 ... 50 / 5 ... 90

¹ Only in rising or falling pipes or tilted horizontal installation

SHARKY FS 473

FLOW SENSOR | ULTRASONIC

TECHNICAL DATA

Nominal flow rate	q_p	m ³ /h	0.6	0.6	0.6	1.5	1.5	1.5	2.5
Nominal diameter	DN	mm	15	20	20	15	20	20	20
Overall length	L	mm	110	130	190	110	130	190	130
Starting flow rate		l/h	1	1	1	2.5	2.5	2.5	4
Minimum flow rate (DR 1:250)	q_i	l/h	6	6	6	6	6	6	10
Minimum flow rate (DR 1:100)	q_i	l/h	6	6	6	15	15	15	25
Minimum flow rate (up side down installation)	q_i	l/h	6	6	6	6	6	6	10
Maximum flow rate	q_s	m ³ /h	1.2	1.2	1.2	3	3	3	5
Overload flow rate		m ³ /h	2.5	2.5	2.5	4.6	4.6	4.6	6.7
Pressure loss at q_p	Δp	mbar	95	85	85	120	75	75	100
Temp. range heating - brass body		°C	5 ... 130	5 ... 130	5 ... 130	5 ... 130	5 ... 130	5 ... 130	5 ... 130
Temp. range heating - spheroidal cast iron body / brass PN 40		°C	-	-	-	-	-	-	-
kv value (q_p^2 (m ³ /h) = $kv^2 \times \Delta p$ (bar))			1.95	2.06	2.06	4.33	5.48	5.48	7.91
Nominal flow rate	q_p	m ³ /h	2.5	3.5	3.5	3.5	3.5	3.5	6
Nominal diameter	DN	mm	20	25	25	25	32	32	25
Overall length	L	mm	190	135	150	260	150	260	135
Starting flow rate		l/h	4	10	10	10	10	10	10
Minimum flow rate (DR 1:250)	q_i	l/h	10	-	-	-	-	-	24
Minimum flow rate (DR 1:100)	q_i	l/h	25	35	35	35	35	35	60
Minimum flow rate (up side down installation)	q_i	l/h	10	35	35	35	35	35	24
Maximum flow rate	q_s	m ³ /h	5	7	7	7	7	7	12
Overload flow rate		m ³ /h	6.7	18.4	18.4	18.4	18.4	18.4	18.4
Pressure loss at q_p	Δp	mbar	100	44	44	44	44	44	128
Temp. range heating - brass body		°C	5 ... 130	5 ... 150	5 ... 150	5 ... 150	5 ... 150	5 ... 150	5 ... 150
Temp. range heating - spheroidal cast iron body / brass PN 40		°C	-	-	-	-	-	-	-
kv value (q_p^2 (m ³ /h) = $kv^2 \times \Delta p$ (bar))			7.91	16.69	16.69	16.69	16.69	16.69	16.77
Nominal flow rate	q_p	m ³ /h	6	6	6	6	6	10	
Nominal diameter	DN	mm	25	25	32	32	40	40	
Overall length	L	mm	150	260	150	260	150	200	
Starting flow rate		l/h	10	10	10	10	10	20	
Minimum flow rate (DR 1:250)	q_i	l/h	24	24	24	24	-	40 ¹	
Minimum flow rate (DR 1:100)	q_i	l/h	60	60	60	60	60	100	
Minimum flow rate (up side down installation)	q_i	l/h	24	24	24	24		100	
Maximum flow rate	q_s	m ³ /h	12	12	12	12	12	20	
Overload flow rate		m ³ /h	18.4	18.4	18.4	18.4	18.4	24	
Pressure loss at q_p	Δp	mbar	128	128	128	128	190	140	
Temp. range heating - brass body		°C	5 ... 150	5 ... 150	5 ... 150	5 ... 150	5 ... 150	5 ... 150	
Temp. range heating - spheroidal cast iron body / brass PN 40		°C	-	-	-	-	-	-	
kv value (q_p^2 (m ³ /h) = $kv^2 \times \Delta p$ (bar))			16.77	16.77	13.76	14.77	13.76	26.73	

SHARKY FS 473

FLOW SENSOR | ULTRASONIC

Nominal flow rate	q_p	m ³ /h	10	15	25	40	60	100
Nominal diameter	DN	mm	40	50	65	80	100	100
Overall length	L	mm	300	270	300	300	360	360
Starting flow rate		l/h	20	40	50	80	120	120
Minimum flow rate (DR 1:250)	q_i	l/h	40 ¹	60 ¹	100 ¹	160 ¹	240 ¹	400 ¹
Minimum flow rate (DR 1:100)	q_i	l/h	100	150	250	400	600/1200 ²	1000/1200 ²
Minimum flow rate (up side down installation)	q_i	l/h	100	150	250	400	1200	1200
Maximum flow rate	q_s	m ³ /h	20	30	50	80	120	120
Overload flow rate		m ³ /h	24	36	60	90	132	132
Pressure loss at q_p	Δp	mbar	140	140	75	80	75	210
Temp. range heating - brass body		°C	5 ... 150	5 ... 150	5 ... 150	5 ... 150	5 ... 150	5 ... 150
Temp. range heating - spheroidal cast iron body / brass PN 40		°C	-	5 ... 105	5 ... 105	5 ... 105	5 ... 105	5 ... 105
kv value (q_p^2 (m ³ /h) = kv ² x Δp (bar))			26.73	40.09	91.29	141.42	219.09	218.22

¹ Valid for horizontal installation only

² Up side down installation

SHARKY FS 473

FLOW SENSOR | ULTRASONIC

DIMENSIONS THREAD VERSION

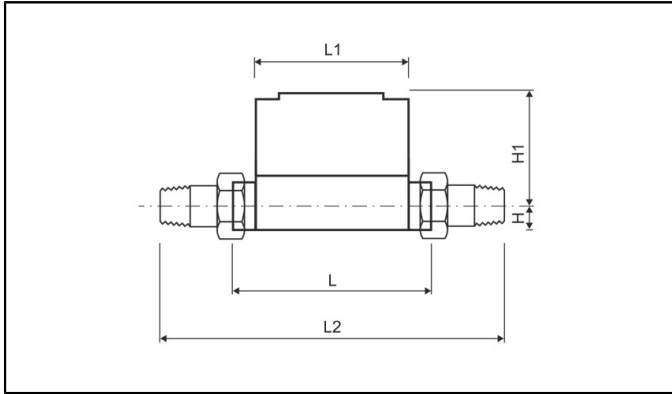

Nominal flow rate	q _p	m ³ /h	0.6	0.6	0.6	1.5	1.5	1.5	2.5
Nominal diameter	DN	mm	15	20	20	15	20	20	20
Overall length	L	mm	110	130	190	110	130	190	130
Overall length with coupling	L2	mm	190	230	-	190	230	-	230
Height	H	mm	14.5	18	18	14.5	18	18	18
Height	H1	mm	54.5	56.5	56.5	54.5	56.5	56.5	56.5
Length of electronic	L1	mm	90	90	90	90	90	90	90
Width of electronic	B	mm	65.5	65.5	65.5	65.5	65.5	65.5	65.5
Connection thread on meter		Inch	G ³ / ₄ B	G1B	G1B	G ³ / ₄ B	G1B	G1B	G1B
Connection thread of coupling		Inch	R ¹ / ₂	R ³ / ₄	R ³ / ₄	R ¹ / ₂	R ³ / ₄	R ³ / ₄	R ³ / ₄
Operating pressure	PN	bar	16/25	16/25	16/25	16/25	16/25	16/25	16/25
Weight		kg	0.6	0.61	0.63	0.6	0.61	0.63	0.61

Nominal flow rate	q _p	m ³ /h	2.5	3.5	3.5	3.5	3.5	3.5	6
Nominal diameter	DN	mm	20	25	25	25	32	32	25
Overall length	L	mm	190	135	150	260	150	260	135
Overall length with coupling	L2	mm	-	255	270	380	270	380	255
Height	H	mm	18	23	23	23	23	23	23
Height	H1	mm	56.5	61	61	61	61	61	61
Length of electronic	L1	mm	90	90	90	90	90	90	90
Width of electronic	B	mm	65.5	65.5	65.5	65.5	65.5	65.5	65.5
Connection thread on meter		Inch	G1B	G1 ¹ / ₄ B	G1 ¹ / ₄ B	G1 ¹ / ₄ B	G1 ¹ / ₂ B	G1 ¹ / ₂ B	G1 ¹ / ₄ B
Connection thread of coupling		Inch	R ³ / ₄	R1	R1	R1	R1 ¹ / ₄	R1 ¹ / ₄	R1
Operating pressure	PN	bar	16/25	16/25	16/25	16/25	16/25	16/25	16/25
Weight		kg	0.63	0.88	0.93	1.35	1.08	1.35	0.88

Nominal flow rate	q _p	m ³ /h	6	6	6	6	6	10	
Nominal diameter	DN	mm	25	25	32	32	40	40	
Overall length	L	mm	150	260	150	260	150	200	
Overall length with coupling	L2	mm	270	380	270	380	-	340	
Height	H	mm	23	23	23	23	33	33	
Height	H1	mm	61	61	61	61	61	66.5	
Length of electronic	L1	mm	90	90	90	90	90	90	
Width of electronic	B	mm	65.5	65.5	65.5	65.5	65.5	65.5	
Connection thread on meter		Inch	G1 ¹ / ₄ B	G1 ¹ / ₄ B	G1 ¹ / ₂ B	G1 ¹ / ₂ B	G2B	G2B	
Connection thread of coupling		Inch	R1	R1	R1 ¹ / ₄	R1 ¹ / ₄	R1 ¹ / ₂	R1 ¹ / ₂	
Operating pressure	PN	bar	16/25	16/25	16/25	16/25	16/25	16/25	
Weight		kg	0.93	1.35	1.08	1.35	1.52	2.4	

SHARKY FS 473

FLOW SENSOR | ULTRASONIC

Nominal flow rate	q _p	m ³ /h	10	15	25	40	60	100
Nominal diameter	DN	mm	40	50	65	80	100	100
Overall length	L	mm	300	270	300	300	360	360
Overall length with coupling	L2	mm	440	-	-	-	-	-
Height	H	mm	33	-	-	-	-	-
Height	H1	mm	66.5	-	-	-	-	-
Length of electronic	L1	mm	90	-	-	-	-	-
Width of electronic	B	mm	65.5	-	-	-	-	-
Connection thread on meter		Inch	G2B	-	-	-	-	-
Connection thread of coupling		Inch	R1½	-	-	-	-	-
Operating pressure	PN	bar	16/25	-	-	-	-	-
Weight		kg	2.6	-	-	-	-	-

SHARKY FS 473

FLOW SENSOR | ULTRASONIC

DIMENSIONS FLANGE VERSION

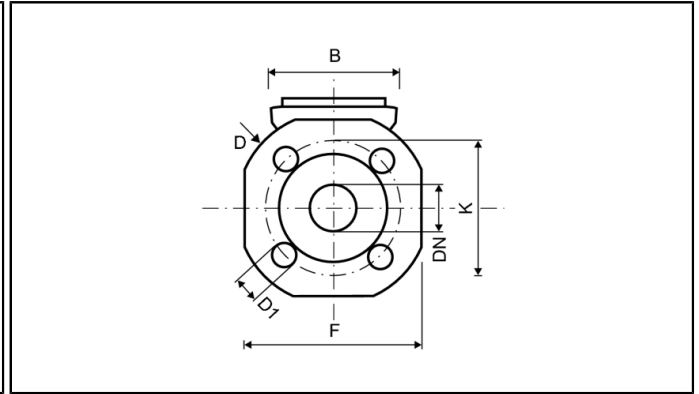
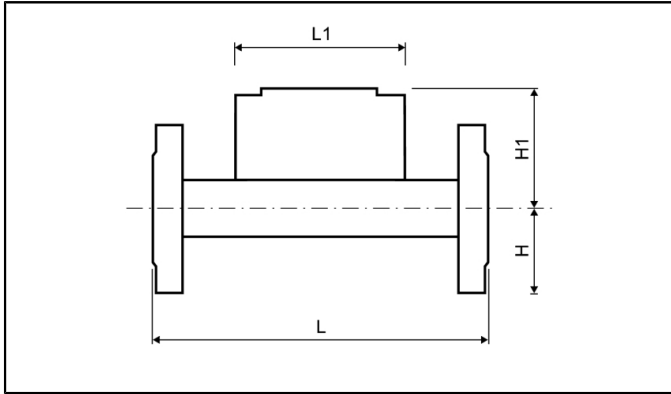

Nominal flow rate	q_p	m^3/h	0.6	0.6	0.6	1.5	1.5	1.5	2.5
Nominal diameter	DN	mm	15	20	20	15	20	20	20
Overall length	L	mm	110	130	190	110	130	190	130
Height	H	mm	-	-	47.5	-	-	47.5	-
Height	H1	mm	-	-	56.5	-	-	56.5	-
Length of electronic	L1	mm	-	-	90	-	-	90	-
Width of electronic	B	mm	-	-	65.5	-	-	65.5	-
Flange dimension	F	mm	-	-	95	-	-	95	-
Flange diameter	D	mm	-	-	105	-	-	105	-
Hole circle diameter	K	mm	-	-	75	-	-	75	-
Screw hole diameter	D1	mm	-	-	14	-	-	14	-
Operating pressure	PN	bar	-	-	16/25	-	-	16/25/40 ³	-
Number of screw holes		pcs	-	-	4	-	-	4	-
Weight brass body ²		kg	-	-	2.7	-	-	2.7	-
Weight spheroidal cast iron body ²		kg	-	-	-	-	-	-	-
Nominal flow rate	q_p	m^3/h	2.5	3.5	3.5	3.5	3.5	3.5	6
Nominal diameter	DN	mm	20	25	25	25	32	32	25
Overall length	L	mm	190	135	150	260	150	260	135
Height	H	mm	47.5	-	-	50	-	62.5	-
Height	H1	mm	56.5	-	-	61	-	61	-
Length of electronic	L1	mm	90	-	-	90	-	90	-
Width of electronic	B	mm	65.5	-	-	65.5	-	65.5	-
Flange dimension	F	mm	95	-	-	100	-	125	-
Flange diameter	D	mm	105	-	-	114	-	139	-
Hole circle diameter	K	mm	75	-	-	85	-	100	-
Screw hole diameter	D1	mm	14	-	-	14	-	18	-
Operating pressure	PN	bar	16/25/40 ³	-	-	16/25/40 ³	-	16/25/40 ³	-
Number of screw holes		pcs	4	-	-	4	-	4	-
Weight brass body ²		kg	2.7	-	-	3.35	-	4.65	-
Weight spheroidal cast iron body ²		kg	-	-	-	-	-	-	-

SHARKY FS 473

FLOW SENSOR | ULTRASONIC

Nominal flow rate	q _p	m ³ /h	6	6	6	6	6	10
Nominal diameter	DN	mm	25	25	32	32	40	40
Overall length	L	mm	150	260	150	260	150	200
Height	H	mm	-	50	-	62.5	-	-
Height	H1	mm	-	61	-	61	-	-
Length of electronic	L1	mm	-	90	-	90	-	-
Width of electronic	B	mm	-	65.5	-	65.5	-	-
Flange dimension	F	mm	-	100	-	125	-	-
Flange diameter	D	mm	-	114	-	139	-	-
Hole circle diameter	K	mm	-	85	-	100	-	-
Screwhole diameter	D1	mm	-	14	-	18	-	-
Operating pressure	PN	bar	-	16/25/40 ³	-	16/25/40 ³	-	-
Number of screwholes		pcs	-	4	-	4	-	-
Weight brass body ²		kg	-	3.35	-	4.65	-	-
Weight spheroidal cast iron body ²		kg	-	-	-	-	-	-
Nominal flow rate	q _p	m ³ /h	10	15	25	40	60	100
Nominal diameter	DN	mm	40	50	65	80	100	100
Overall length	L	mm	300	270	300	300	360	360
Height	H	mm	69	73.5	85	92.5	108	108
Height	H1	mm	66.5	71.5	79	86.5	96.5	95.5
Length of electronic	L1	mm	90	90	90	90	90	90
Width of electronic	B	mm	65.5	65.5	65.5	65.5	65.5	65.5
Flange dimension	F	mm	138	147	170	185	216	216
Flange diameter	D	mm	148	163	184	200	235	235
Hole circle diameter	K	mm	110	125	145	160	180 ¹ / 190	180 ¹ / 190
Screwhole diameter	D1	mm	18	19	19	19	19 ¹ / 22	19 ¹ / 22
Operating pressure	PN	bar	16/25/40 ³	16/25/40 ³	16/25	16/25/40 ³	16/25	16/25
Number of screwholes		pcs	4	4	8	8	8	8
Weight brass body ²		kg	6.6	7.45	9.45	11.1	16.9	16.9
Weight spheroidal cast iron body ²		kg	-	6.31	8.08	10.01	15.76	15.75

¹ Values for PN 16 housing

² Meter with battery and 2.4 m cable length of the pulse cable

³ Only up to 105 °C

PRESSURE LOSS GRAPH / TYPICAL ERROR GRAPH

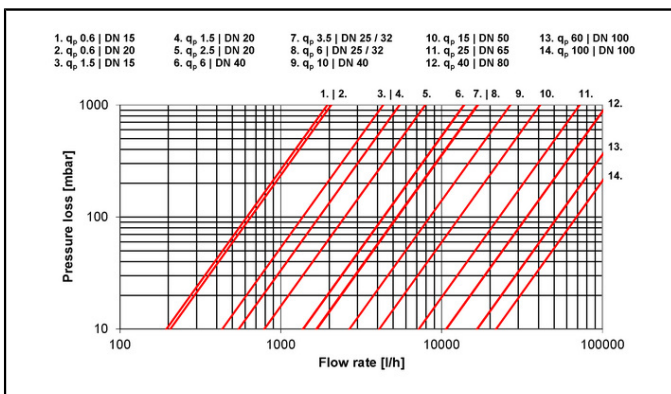

Pressure loss graph

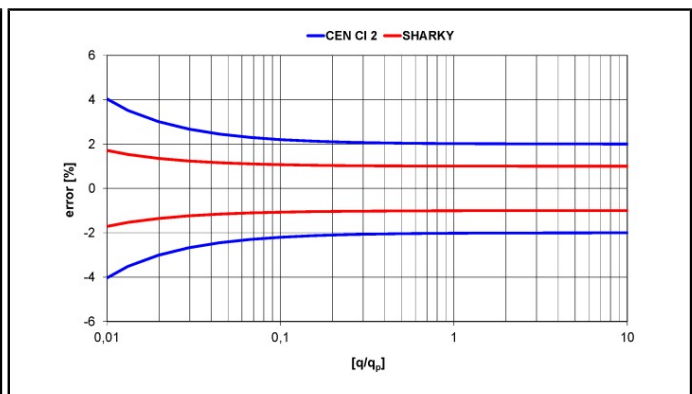

Typical error graph